

DATASHEET

ORIGINALNAi LED-160-NAI-GPS

- For use as a 5 nautical mile beacon on offshore wind turbine
- Maintenance-free LED technology
- Standard NAI bus interface for power supply and communication
- Suitable for series connection of multiple NAI component
- Exact day-night switching and GPS-precise synchronisation of all flashcode generators according to IALA standard in the NAI network

This nautical lantern is intended for use on offshore wind turbines. It satisfies the requirements of the IALA recommendation O-139¹ and the guideline 'offshore structures' of the WSV² according to the 'Technical Requirements' TF01 '5 nautical mile beacon (yellow)'.

The device is distinguished by low power consumption, a long service life and robust construction. Equipped with light emitting diodes (LEDs) as light sources the optical systems is designed for long maintenance intervals. Utilising LED technology provides the greatest possible light output.

The lantern's integrated NAI bus interface is used to supply power, to control the flashcode and intensity, and to transmit status and error messages to the central NAI controller, so that they are available to the central SCADA system.

The integrated GPS module provides day-night information and synchronisation pulses for the flashcodes in the network of a structure marking system, based on a very precise GPS/GLONASS time base and an integrated ambient light sensor.

¹ IALA Recommendations O-139, "The marking of man-made offshore structures"
² Wasser-und Schifffahrtsverwaltung des Bundes

The day-night switching occurs depending

- on the ambient brightness and
- the current date in conjunction with the Cuxhaven calendar (North Sea or Baltic Sea) or
- the geographic position of the device according to the astronomical clock.

The exact flashcode synchronisation of the connected navigation light components is guaranteed even in the event of a weak or absent GPS/GLONASS signal over a time period of at least 2 hours.

Dimensions & Weight

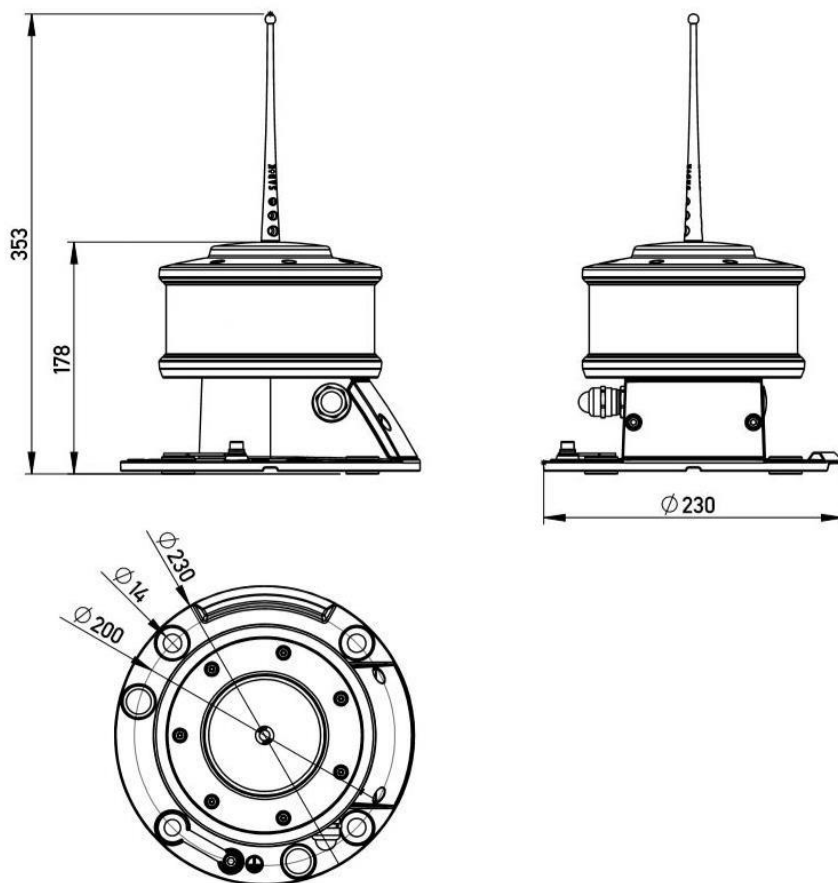

Diameter optics	160 mm
Diameter mounting foot	230 mm
Height without bird spikes	178 mm
Weight incl. mounting foot	2.55 kg

Material

Housing (Device foot, head, cover for socket)	Anodised, powder-coated aluminium (AlSi12)
Lens	PMMA
Lens cover	PMMA
Cable gland	Nickel-plated brass
Earthing connection	Nickel-plated brass
Cover indicator LED	PMMA
Insulation sleeve	PA
Seals	TPE, injection-molded
Pressure compensation valve for socket and housing	PTFE membrane

Optical System

Light colour	Yellow
Maximum light intensity (along the optical axis)	approx. 140 cd
Beam angle (vertical)	8° (FWHM)

Components



- 1. Device head with optics and bird spike
- 2. Housing cover for socket with spring terminal block
- 3. Indicator LED, light sensor
- 4. Second cable gland M20 or blanking plug
- 5. Device foot with integrated socket and third cable gland M20 or blanking plug on the bottom side
- 6. Cable gland M20
- 7. Earthing connection



Note: All housing components including the cable glands satisfy the IP67 degree of protection requirements according to IEC 60529. During connection and assembly, ensure that no moisture or dirt penetrates into the open socket.

	Size	For cable diameter	Key width
EMC Cable Gland	M20 x 1.5	7.5 – 14.0 mm	24 mm

Electrical Connection

Electrical connection	Spring terminal block, max. 2.5 mm ²
Operating voltage V _{IN}	19 to 36 V DC
Power consumption (V _{IN} = 24 V DC – max. intensity)	max. 2 W

Electrical connection

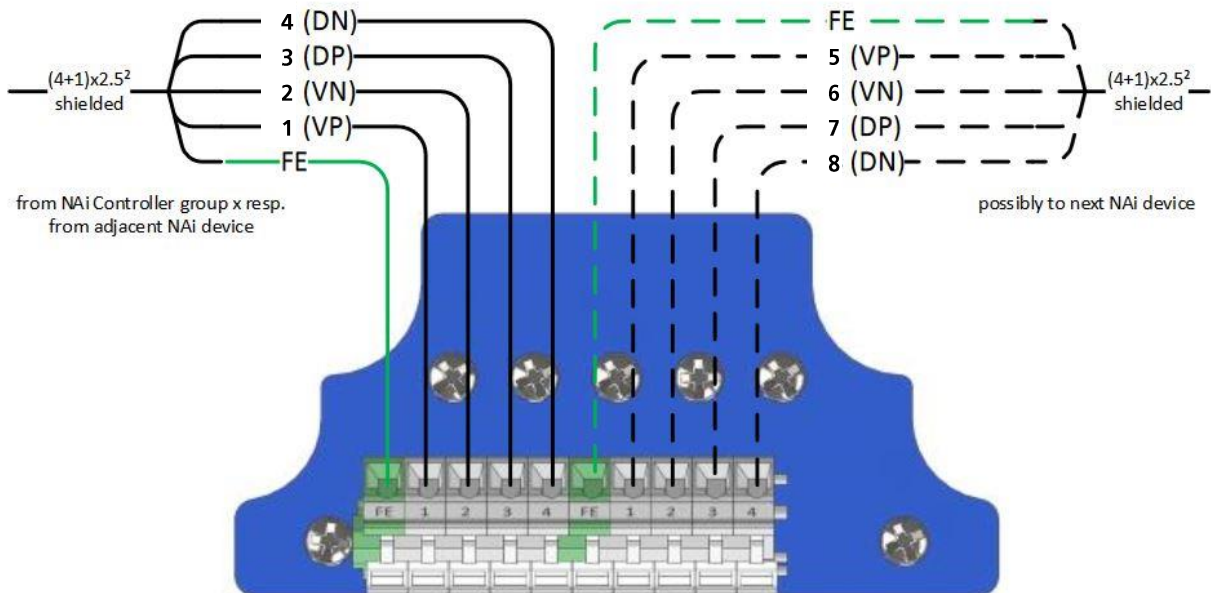

1	VPI	Power supply input (Positive)
2	VN	Power supply input (Negative)
3	DP	NAi data (Positive)
4	DN	NAi data (Negative)
5	VPO	Power supply output (Positive – to next device)
6	VN'	Power supply output (Negative – to next device)
7	DP'	NAi data (Positive – to next device)
8	DN'	NAi data (Negative – to next device)

Environmental Conditions

Regulations	IEC 60945, device type 'exposed'
Ambient temperature (operation)	-40 °C to 55 °C
Ambient temperature (storage / transport)	-40 °C to 70 °C
Humidity (operation / storage / transport)	Max. 95 % acc. To IEC 60945
Atmospheric pressure (operation / storage / transport)	80 kPa to 108 kPa
Degree of protection (acc. to IEC 60529)	IP67

Electrical Safety and Health

Protection class	Class III
Overvoltage protection	Class III
Pollution degree	3

Reliability

MTBF Electronics	2 130 000 h
Minimum LED lifetime	100 000 h

Compliance

Electromagnetic Compatibility	EN 60945:2002, category "exposed" EN 61000-6-2:2005 EN 301 489-1 V2.1.1 EN 301 489-19 V2.1.0
Environmental	EN 60945:2002, category "exposed" IEC 61892-1:2019 EN 60598-1:2015 + A1:2008
Product safety	EN 60598-1:2015 + A1:2018
Mechanical	EN 60945:2002, category "exposed" EN 60598-1:2015 + A1:2018 EN 61892-3:2019

Ordering Information

Item Number	Product ID	Details
30 40 12 00	LED-160-NAI-GPS	-